

**NOW!** LOCK PREP IN  
LESS THAN 3 MIN.  
WHILE DOOR IS GLAZED & HUNG

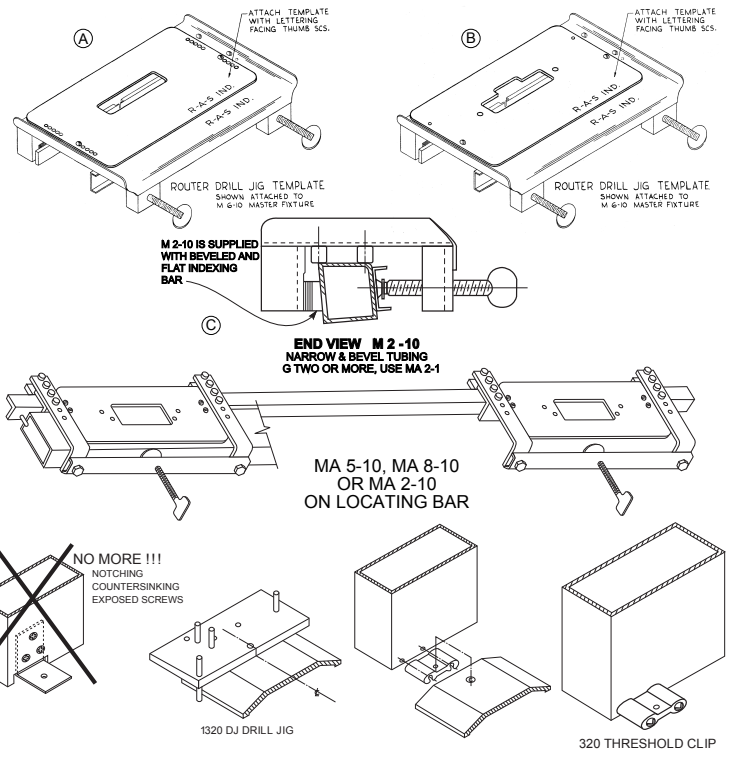

- |                   |                           |                           |
|-------------------|---------------------------|---------------------------|
| <b>DRILL JIGS</b> | <b>ROUTER-DRILL JIGS</b>  | <b>NOTCHING SAWS</b>      |
| <b>DRILL BITS</b> | <b>ROUTER BITS</b>        | <b>SCREWS</b>             |
| <b>BRACKETS</b>   | <b>BACK UP PLATES</b>     | <b>COOLANT (KOOL-CUT)</b> |
| <b>CLIPS</b>      | <b>REINFORCING PLATES</b> | <b>COOLANT SYSTEMS</b>    |

**TEMPLATES FOR ELU, WEGOMA OR OTHER COPY ROUTERS, SPECIAL JIGS, DRILL-JIGS, ROUTER TEMPLATES, BRACKETS, AND REINFORCING PLATES MADE TO CUSTOMER SPECIFICATIONS**

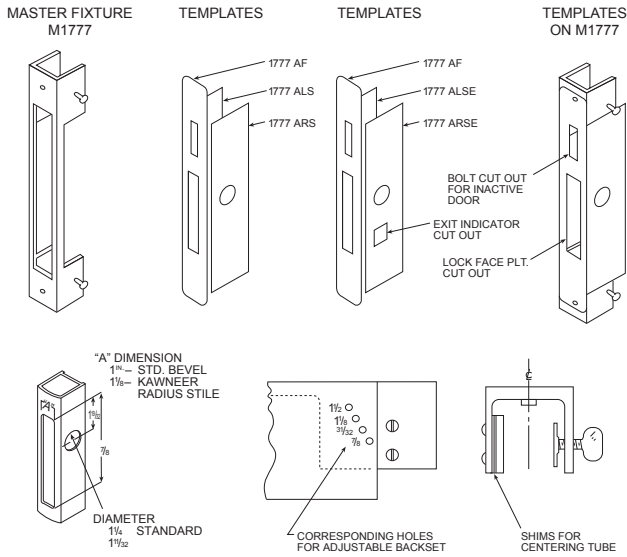

**TOOLS • SYSTEMS • ACCESSORIES**