

**SECTION E - TOP OFFSET PIVOT  
 REINFORCING PLATES - ROUTER TEMPLATES - DRILL JIGS**

ROUTER TEMPLATE OR DRILL JIG	DESCRIPTION	MISC. INFO.	REINFORCING PLATE	PAGE
RIX 1025 AT	ROUTER TEMPLATE		RIX 25A	E-2
RIX 1025 AJ	DRILL JIG			
1412	ROUTER DRILL JIG TEMPLATE SEE PAGE B-10		NOT REQUIRED	E-4
1422				
1417		JACKSON SEE NOTE KAWNEER		E-5
1437				
1442				E-6
1407 PA				
1447		U.S. ALUM		E-7
1432		HOWMET		

SEE SPECIFIC PAGE FOR FULL PART NUMBER BEFORE ORDERING

NOTE - OTHER MANUFACTURERS USING JACKSON TOP OFFSET PIVOT  
 ALUMILINE - REBCO - ARCH ALUMINUM

NOTE - ROUTER TEMPLATE GUIDE MUST BE USED WITH R-A-S ROUTER TEMPLATES. SEE PAGE J-5.

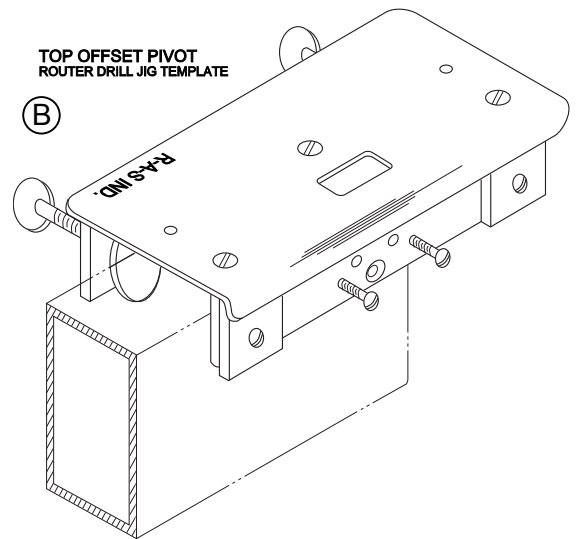
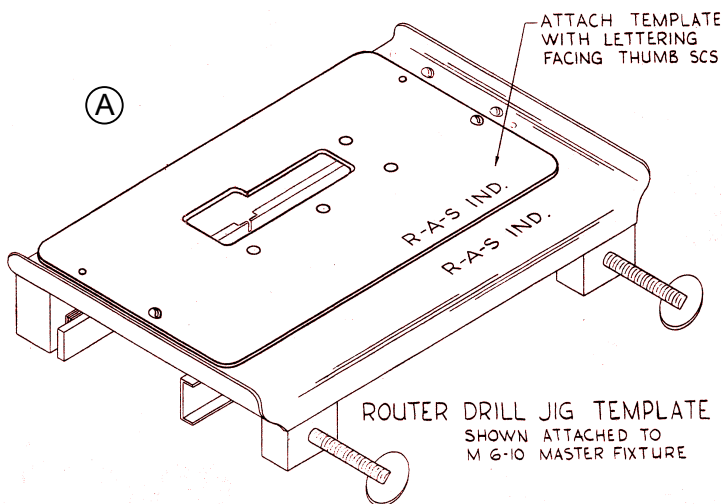

**EXPLODED VIEW**

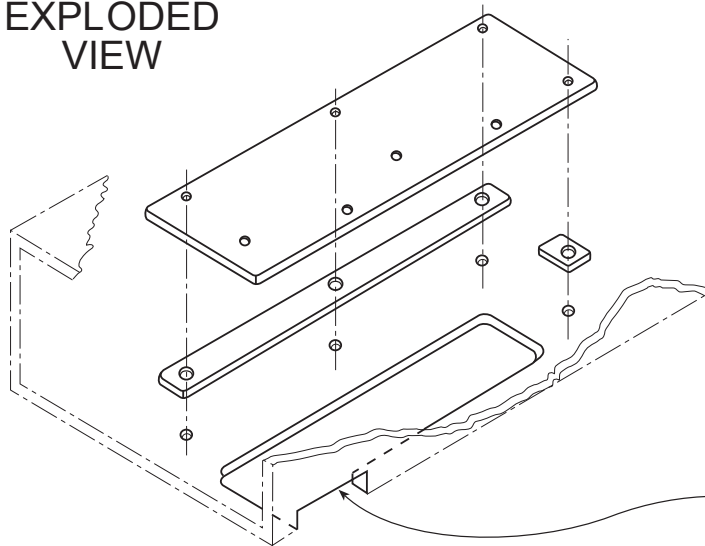

ROUTER TEMPLATE 1025T RH  
SHOWN AS IT WOULD  
APPEAR ON INVERTED  
HEADER (1/2 SIZE)

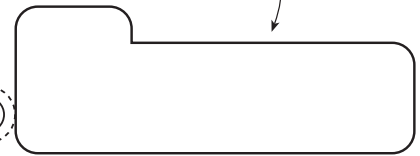

STOP LOCATES  
CUT OUT FROM  
END OF TUBE

TOP OFF-SET PIVOT CUT OUT IN DOOR HEADER  
USE R-A-S ROUTER TEMPLATE 1025T RH OR  
1025T LH AND DRILL JIG 1025DJ FOR 1/8 SET-BACK.  
TEMPLATES AND JIGS AVAILABLE FOR OTHER SET-BACKS.

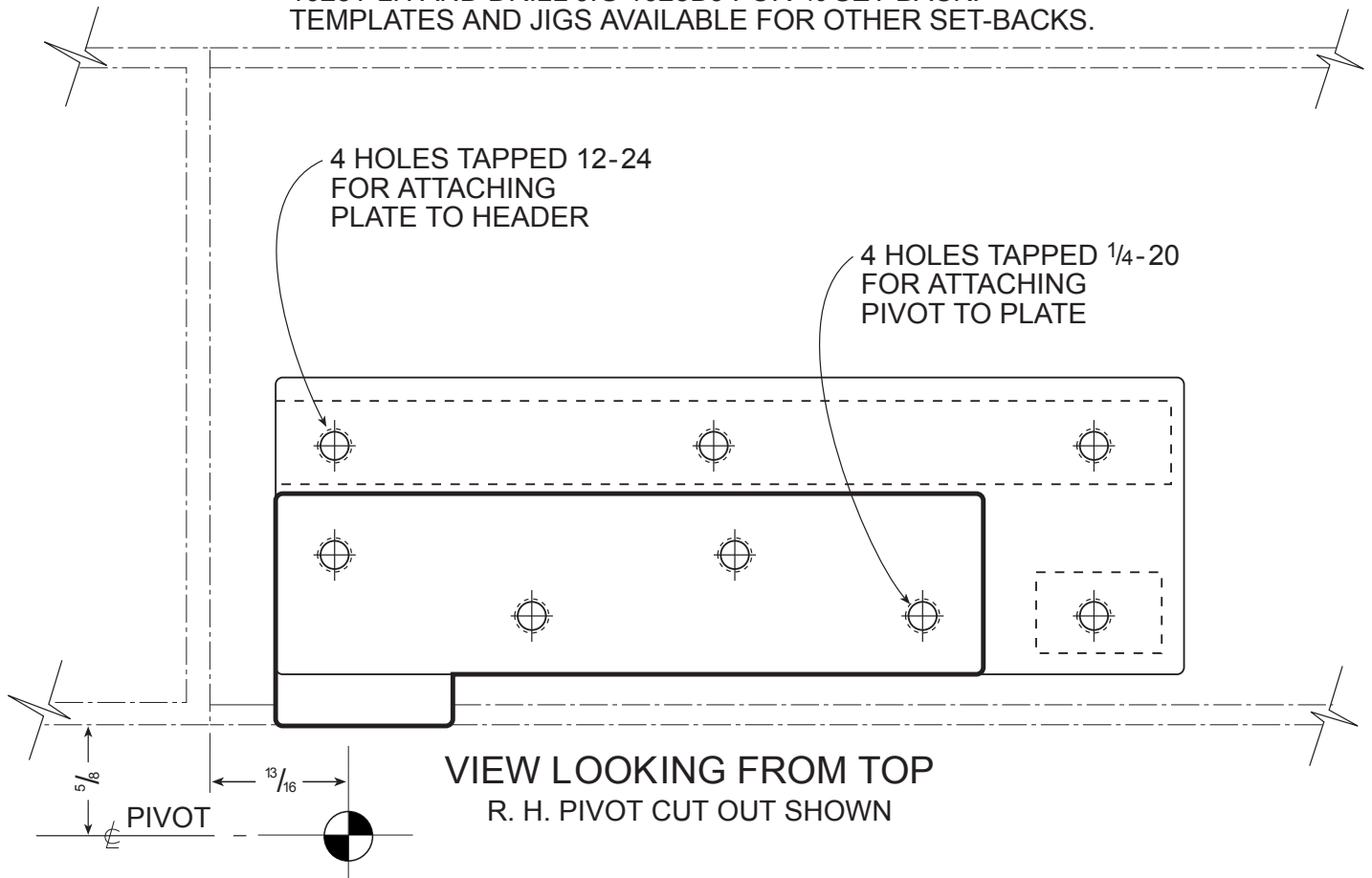

SEE PAGE B-10

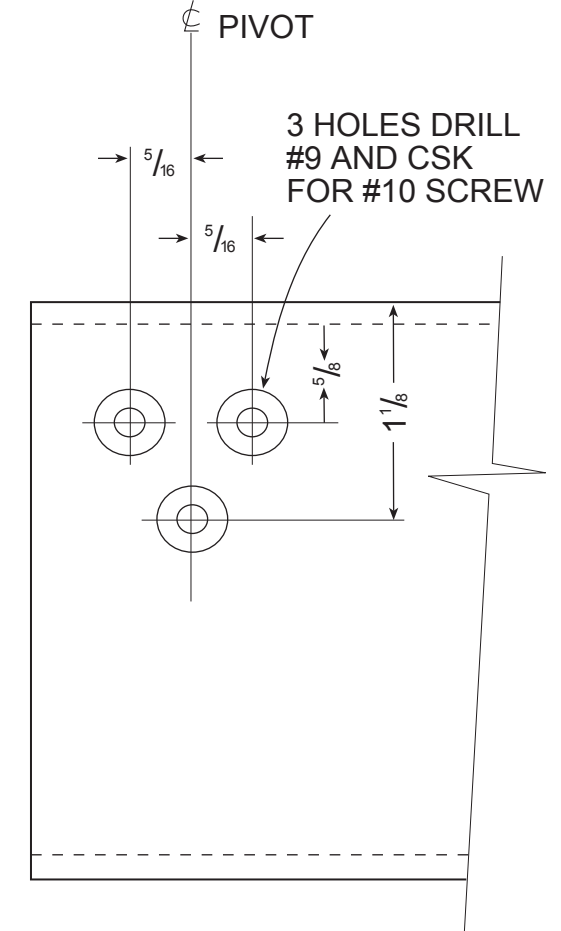
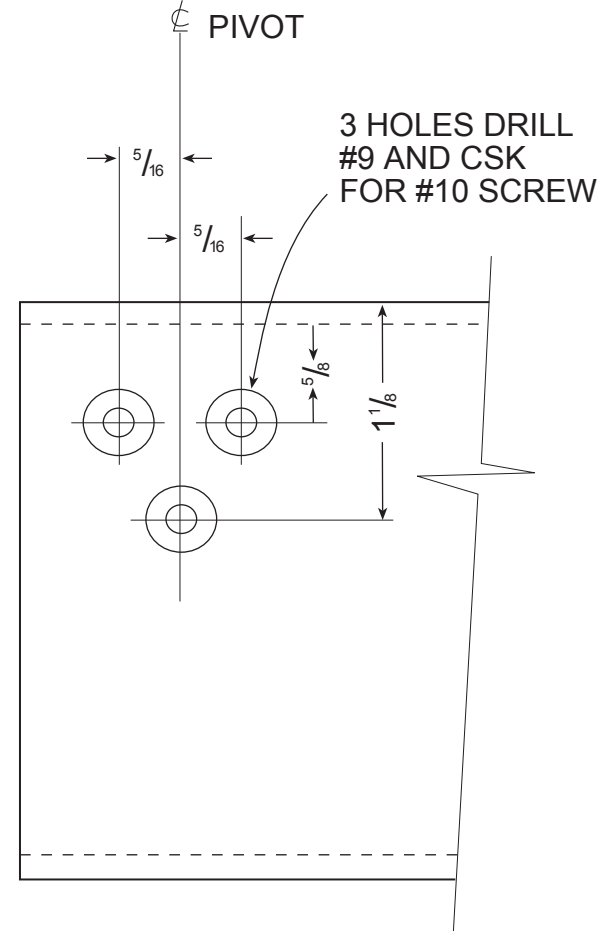
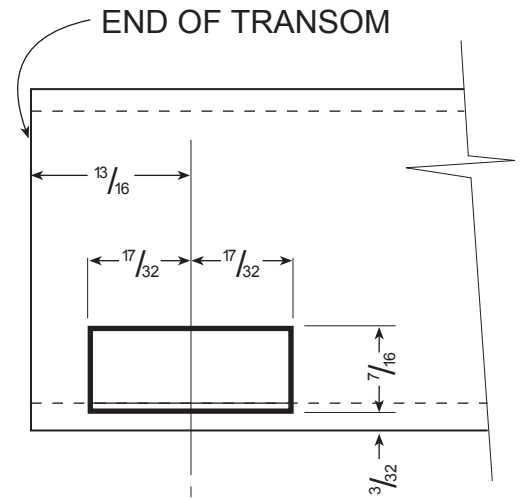
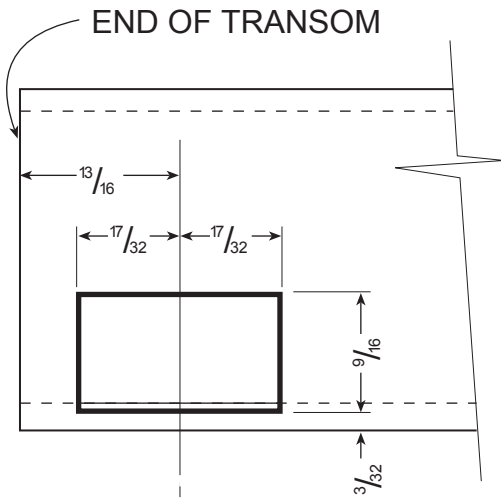
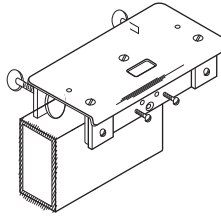

**1412 ROUTER DRILL  
 JIG TEMPLATE**  
 CUT OUT & HOLE PATTERN  
 ALDORA

**1422 ROUTER DRILL  
 JIG TEMPLATE**  
 CUT OUT & HOLE PATTERN  
 AMARLITE

SEE PAGE B-10

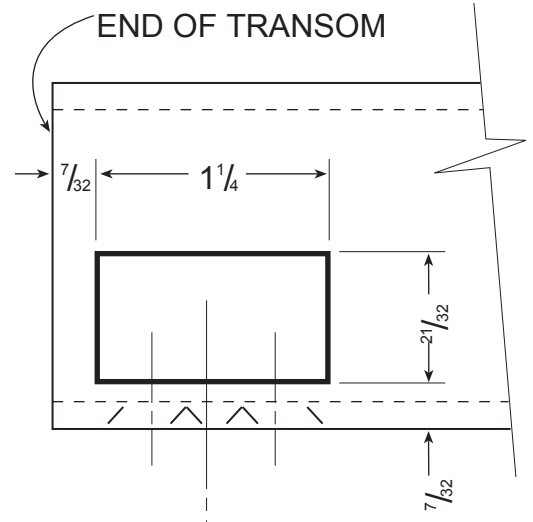
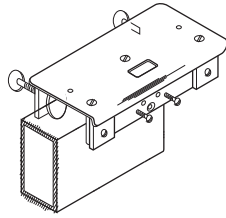
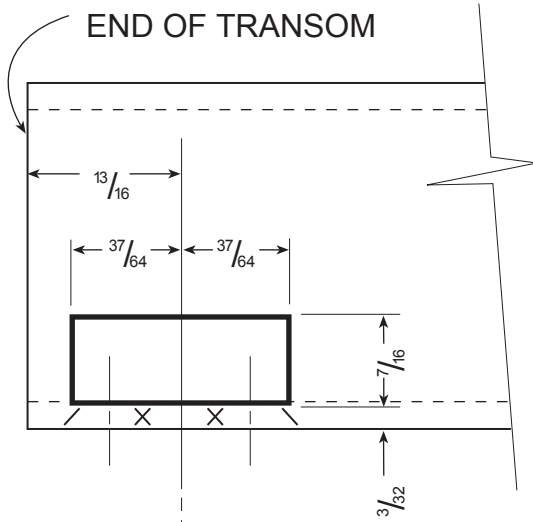

PIVOT

PIVOT

3 HOLES DRILL  
 #2 AND CSK  
 FOR #12 SCREW

3 HOLES DRILL  
 #2 AND CSK  
 FOR #12 SCREW

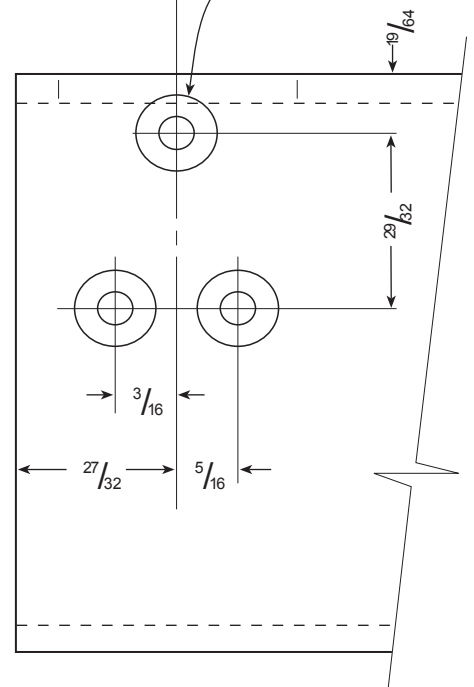
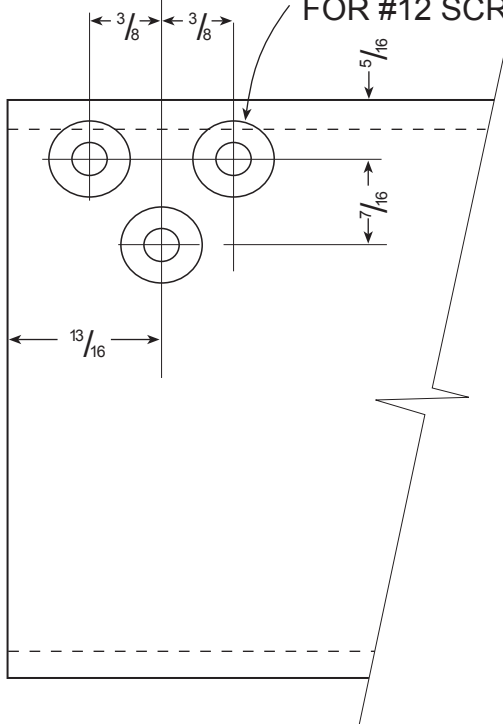

**1417 ROUTER DRILL  
 JIG TEMPLATE**  
 CUT OUT & HOLE PATTERN  
 JACKSON  
 SEE NOTE PAGE E-1

**1437 ROUTER DRILL  
 JIG TEMPLATE**  
 CUT OUT & HOLE PATTERN  
 KAWNEER

SEE PAGE B-10

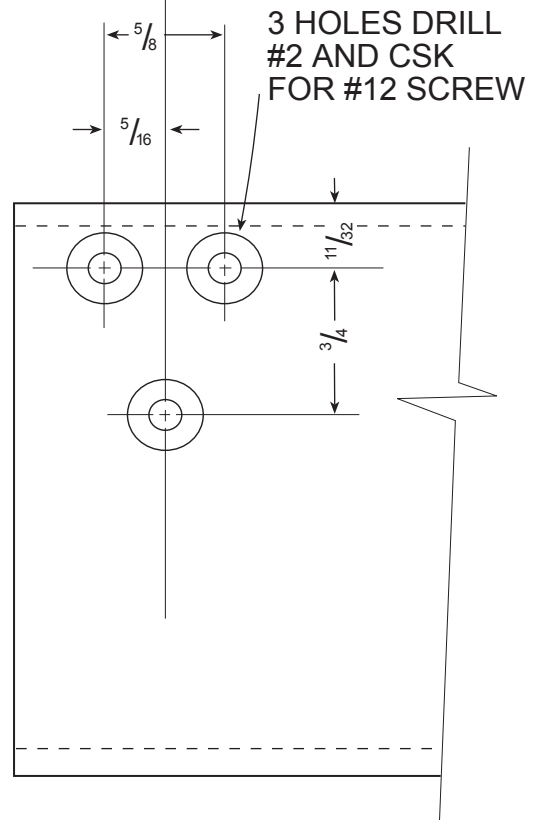
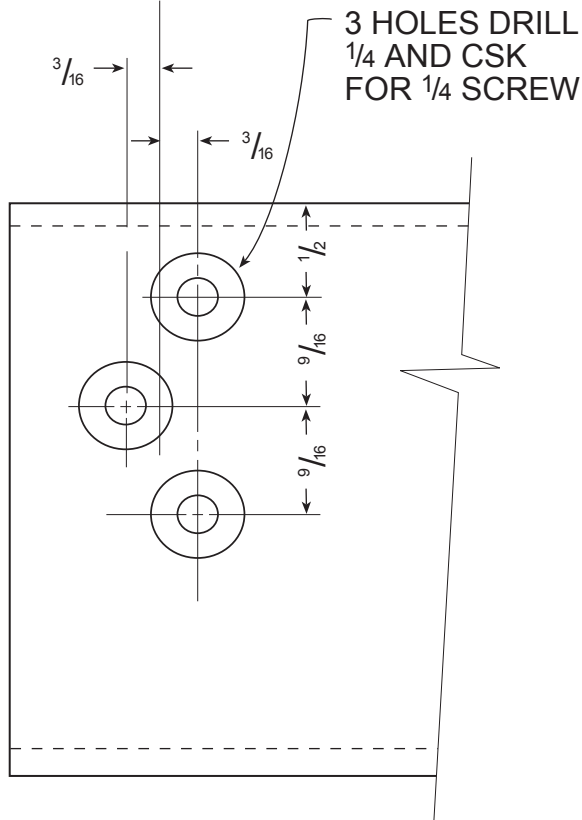
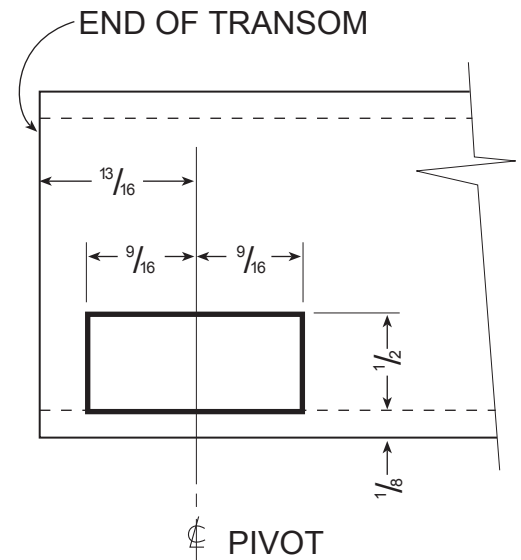
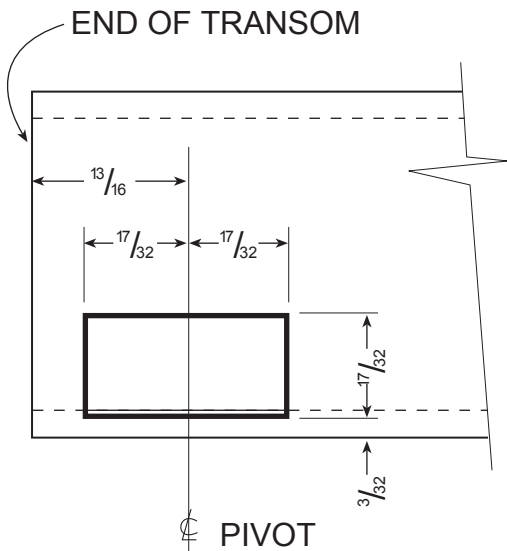
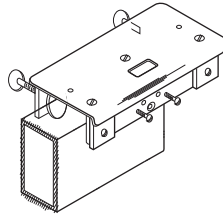

**1442 ROUTER DRILL  
 JIG TEMPLATE**  
 CUT OUT & HOLE PATTERN  
 EXTRUDART

**1407-PA ROUTER DRILL  
 JIG TEMPLATE**  
 CUT OUT & HOLE PATTERN  
 PITTCO

SEE PAGE B-10

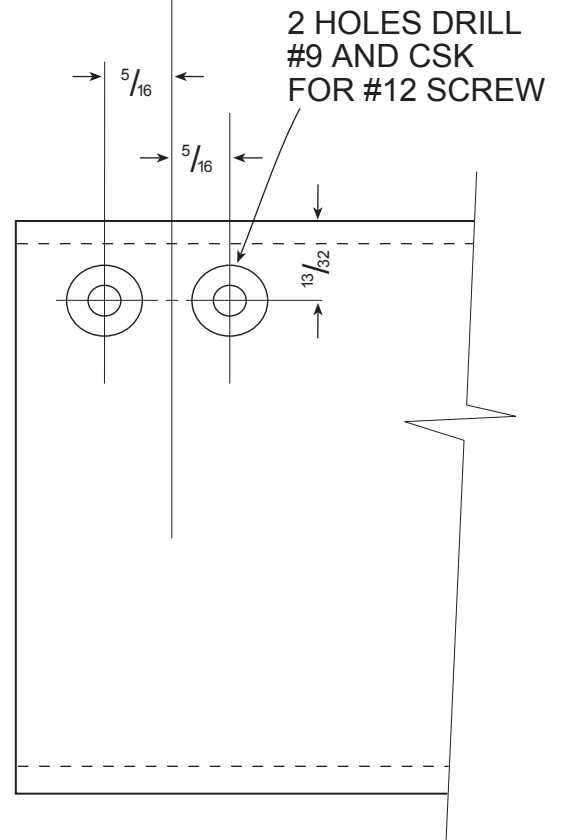
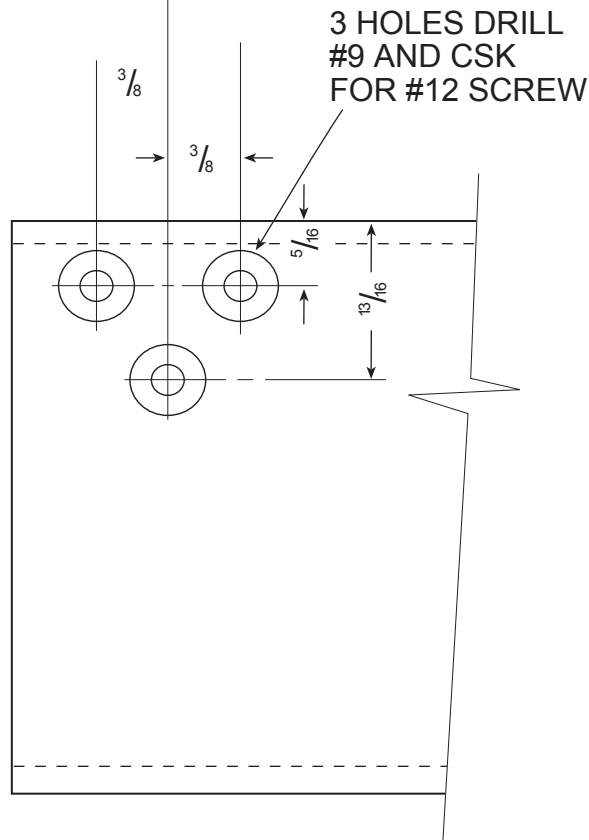
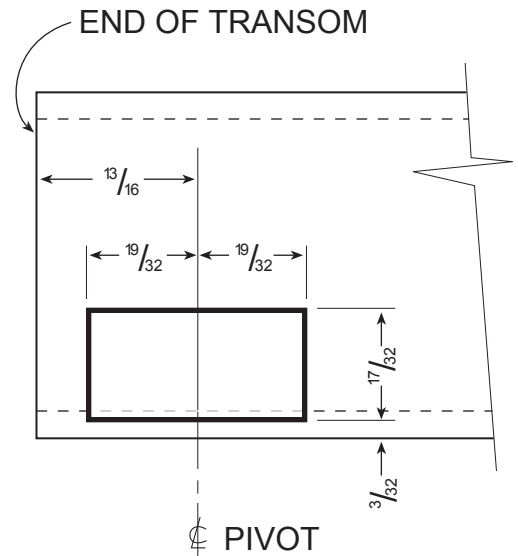
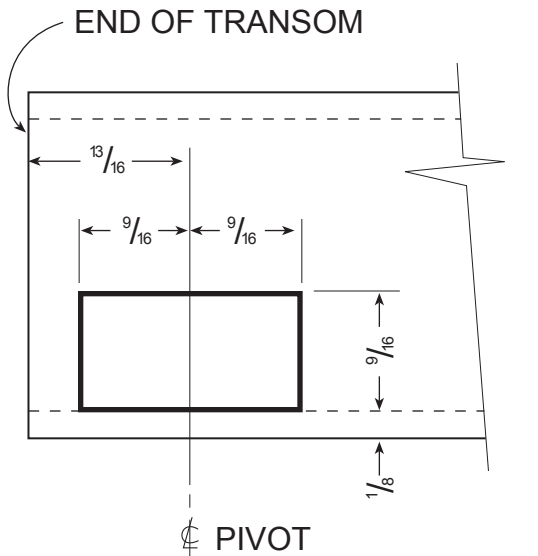
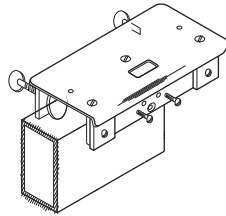

**1432 ROUTER DRILL  
 JIG TEMPLATE**  
 CUT OUT & HOLE PATTERN  
 HOWMET VISTAWALL

**1447 ROUTER DRILL  
 JIG TEMPLATE**  
 CUT OUT & HOLE PATTERN  
 U. S. ALUMINUM